



HINO 7000 Series



*THE RIGHT TRUCK
FOR AFRICA*

DESCRIPTION	Hino 700 2038	Hino 700 2841	
VEHICLE CONFIGURATION	4 x 2	6 X 4	6 X 4
Application	Truck Tractor	Truck Tractor	
Suspensions	Steel	Steel	Steel
Cab	Single Sleeper Cab	Single Sleeper Cab	Double Sleeper Cab
Drivetrain	4x2	6x4	6x4

DESCRIPTION	Hino 700 2038	Hino 700 2841	
-------------	---------------	---------------	--

ENGINE

Make and Model	Hino E13C-VU	Hino E13C TN	Hino E13C TN
4 Stroke Compression Ignition	Yes	Yes	Yes
Aspiration	Turbo Intercooled	Turbo Intercooled	Turbo Intercooled
Bore X Stroke	137x146	137x146	137x146
Capacity (cc)	12 913	12 913	12 913
Compression Ratio : ~ : 1	17.5	17.5	17.5
Configuration	6 Cyl In Line	6 Cyl In Line	6 Cyl In Line
Engine oil cooler	Yes	Yes	Yes
Euro Emission Status	2	2	2
Firing order	1-4-2-6-3-5	1-4-2-6-3-5	1-4-2-6-3-5
Governor : All speed / RLD	Yes	Yes	Yes
Governor : Electronic	Yes	Yes	Yes
Injection System	Common Rail	Common Rail	Common Rail
Injector Pump	Electronic Control High Pressure Pump	Electronic Control High Pressure Pump	Electronic Control High Pressure Pump
Max Eng. Speed rpm	1 900	1 900	1 900
No of Main Bearings	7	7	7
Number of Cylinders	6	6	6
Number of Valves per Cylinders	4	4	4
Power (EEC/ISO NET) (kW @ r/min)	279 @ 1 800	302 @ 1 800	302 @ 1 800
Torque (Nm @ r/min)	1 814 @ 1 100	1 863 @ 1 100	1 863 @ 1 100
Type of Cylinders (Liners; wet or dry)	Dry Liners	Dry Liners	Dry Liners
Valve Configuration	Overhead Camshaft	Overhead Camshaft	Overhead Camshaft

DESCRIPTION	Hino 700 2038	Hino 700 2841	
-------------	---------------	---------------	--

TRANSMISSION

Make	ZF AS Tronic AMT	ZF AS Tronic AMT	ZF AS Tronic AMT
Model	16 AS2630TO	16 AS2630TO	16 AS2630TO
No of forward gears	16	16	16
Constant / Synchro mesh	Constant 1st - 16th	Constant 1st - 16th	Constant 1st - 16th
Gear Ratio (Low / High) 1:	14.120 / 0.827	14.120 / 0.827	14.120 / 0.827
Gearshift operation	Mech / Auto	Mech / Auto	Mech / Auto
PTO & Control	Non Standard	Non Standard	Non Standard
Reverse Ratio (Low / High) 1:	13.074 / 10.812	13.074 / 10.812	13.074 / 10.812

DESCRIPTION	Hino 700 2038	Hino 700 2841	
-------------	---------------	---------------	--

BRAKES

ABS	Yes	Yes	Yes
Brake system : Front	DRUM	DRUM	DRUM
Brake system : Rear	DRUM	DRUM	DRUM
Dual Circuit	Yes	Yes	Yes
Type :	Full air	Full air	Full air

DESCRIPTION	Hino 700 2038	Hino 700 2841	
-------------	---------------	---------------	--

STEERING

Ratio 1:	23.4	23.4	23.4
Steering Column	Tilt & Telescopic	Tilt & Telescopic	Tilt & Telescopic
Turning radius between kerbs : (mm)	6 200	7 200	7 200
Turning radius between walls : (mm)	7 100	8 100	8 100
Type	Power assisted; re-circulating ball	Power assisted; re-circulating ball	Power assisted; re-circulating ball

DESCRIPTION	Hino 700 2038	Hino 700 2841	
-------------	---------------	---------------	--

WHEELS & TYRES

Attachment	10 Stud ISO Type	10 Stud ISO Type	10 Stud ISO Type
Load Index (Single / Dual) Kg	3 750 / 3 750	3 750 / 3 350	3 750 / 3 350
Speed Index Km/h	130	130	130
No of Wheels including spare	7	11	11
Spare Wheel Fitment	Strapped to chassis	Strapped to chassis	Strapped to chassis
Tyre Construction	Radial Tubeless	Radial Tubeless	Radial Tubeless
Tyre size	315/80R22.5 156/150 M	315/80R22.5 156/150 M	315/80R22.5 156/150 M
Wheel size	9.00x22.5-offset 175mm	9.00x22.5-offset 175mm	9.00x22.5-offset 175mm
Wheel Type	Single Piece Steel	Single Piece Steel	Single Piece Steel

DESCRIPTION	Hino 700 2845	Hino 700 3541	
VEHICLE CONFIGURATION	6 X 4	8 X 4	
Application	Truck Tractor	Tipper	Freight Carrier
Suspensions	Steel	Steel	Steel
Cab	Single Sleeper Cab	Single Sleeper Cab	Single Sleeper Cab
Drivetrain	6x4	8x4	8x4

DESCRIPTION	Hino 700 2845	Hino 700 3541	
-------------	---------------	---------------	--

ENGINE

Make and Model	Hino E13C TT	Hino E13C TN	Hino E13C TN
4 Stroke Compression Ignition	Yes	Yes	Yes
Aspiration	Turbo Intercooled	Turbo Intercooled	Turbo Intercooled
Bore X Stroke	137x146	137x146	137x146
Capacity (cc)	12 913	12 913	12 913
Compression Ratio : ~ : 1	17.5	17.5	17.5
Configuration	6 Cyl In Line	6 Cyl In Line	6 Cyl In Line
Engine oil cooler	Yes	Yes	Yes
Euro Emission Status	2	2	2
Firing order	1-4-2-6-3-5	1-4-2-6-3-5	1-4-2-6-3-5
Governor : All speed / RLD	Yes	Yes	Yes
Governor : Electronic	Yes	Yes	Yes
Injection System	Common Rail	Common Rail	Common Rail
Injector Pump	Electronic Control High Pressure Pump	Electronic Control High Pressure Pump	Electronic Control High Pressure Pump
Max Eng. Speed rpm	1 900	1 900	1 900
No of Main Bearings	7	7	7
Number of Cylinders	6	6	6
Number of Valves per Cylinders	4	4	4
Power (EEC/ISO NET) (kW @ r/min)	331 @ 1 800	302 @ 1 800	302 @ 1 800
Torque (Nm @ r/min)	2 157 @ 1 100	1 863 @ 1 100	1 863 @ 1 100
Type of Cylinders (Liners; wet or dry)	Dry Liners	Dry Liners	Dry Liners
Valve Configuration	Overhead Camshaft	Overhead Camshaft	Overhead Camshaft

DESCRIPTION	Hino 700 2845	Hino 700 3541	
-------------	---------------	---------------	--

TRANSMISSION

Make	ZF AS Tronic AMT	ZF AS Tronic AMT	ZF AS Tronic AMT
Model	16 AS2630TO	16 AS2630TO	16 AS2630TO
No of forward gears	16	16	16
Constant / Synchro mesh	Constant 1st - 16th	Constant 1st - 16th	Constant 1st - 16th
Gear Ratio (Low / High) 1:	14.120 / 0.827	14.120 / 0.827	14.120 / 0.827
Gearshift operation	Mech / Auto	Mech / Auto	Mech / Auto
PTO & Control	Non Standard	Non Standard	Non Standard
Reverse Ratio (Low / High) 1:	13.074 / 10.812	13.074 / 10.812	13.074 / 10.812

DESCRIPTION	Hino 700 2845	Hino 700 3541	
-------------	---------------	---------------	--

BRAKES

ABS	Yes	Yes	Yes
Brake system : Front	DRUM	DRUM	DRUM
Brake system : Rear	DRUM	DRUM	DRUM
Dual Circuit	Yes	Yes	Yes
Type :	Full air	Full air	Full air

DESCRIPTION	Hino 700 2845	Hino 700 3541	
-------------	---------------	---------------	--

STEERING

Ratio 1:	23.4	25.2	25.2
Steering Column	Tilt & Telescopic	Tilt & Telescopic	Tilt & Telescopic
Turning radius between kerbs : (mm)	7 200	11 400	11 700
Turning radius between walls : (mm)	8 100	12 300	12 600
Type	Power assisted; re-circulating ball	Power assisted; re-circulating ball	Power assisted; re-circulating ball

DESCRIPTION	Hino 700 2845	Hino 700 3541	
-------------	---------------	---------------	--

WHEELS & TYRES

Attachment	10 Stud ISO Type	10 Stud ISO Type	10 Stud ISO Type
Load Index (Single / Dual) Kg	3 750 / 3 350	3 750 / 3 350	3 750 / 3 350
Speed Index Km/h	130	130	130
No of Wheels including spare	11	13	13
Spare Wheel Fitment	Strapped to chassis	Temporary Bracket	Carrier on Chassis
Tyre Construction	Radial Tubeless	Radial Tubeless	Radial Tubeless
Tyre size	315/80R22.5 156/150 M	315/80R22.5 156/150 M	315/80R22.5 156/150 M
Wheel size	9.00x22.5-offset 175mm	9.00x22.5-offset 175mm	9.00x22.5-offset 175mm
Wheel Type	Single Piece Steel	Single Piece Steel	Single Piece Steel

DESCRIPTION	Hino 700 2038	Hino 700 2841	
VEHICLE CONFIGURATION	4 x 2	6 X 4	6 X 4
Application	Truck Tractor	Truck Tractor	
Suspensions	Steel	Steel	Steel
Cab	Single Sleeper Cab	Single Sleeper Cab	Double Sleeper Cab
Drivetrain	4x2	6x4	6x4

DESCRIPTION	Hino 700 2038	Hino 700 2841	
-------------	---------------	---------------	--

ENGINE

Make and Model	Hino E13C-VU	Hino E13C TN	Hino E13C TN
4 Stroke Compression Ignition	Yes	Yes	Yes
Aspiration	Turbo Intercooled	Turbo Intercooled	Turbo Intercooled
Bore X Stroke	137x146	137x146	137x146
Capacity (cc)	12 913	12 913	12 913
Compression Ratio : ~ : 1	17.5	17.5	17.5
Configuration	6 Cyl In Line	6 Cyl In Line	6 Cyl In Line
Engine oil cooler	Yes	Yes	Yes
Euro Emission Status	2	2	2
Firing order	1-4-2-6-3-5	1-4-2-6-3-5	1-4-2-6-3-5
Governor : All speed / RLD	Yes	Yes	Yes
Governor : Electronic	Yes	Yes	Yes
Injection System	Common Rail	Common Rail	Common Rail
Injector Pump	Electronic Control High Pressure Pump	Electronic Control High Pressure Pump	Electronic Control High Pressure Pump
Max Eng. Speed rpm	1 900	1 900	1 900
No of Main Bearings	7	7	7
Number of Cylinders	6	6	6
Number of Valves per Cylinders	4	4	4
Power (EEC/ISO NET) (kW @ r/min)	279 @ 1 800	302 @ 1 800	302 @ 1 800
Torque (Nm @ r/min)	1 814 @ 1 100	1 863 @ 1 100	1 863 @ 1 100
Type of Cylinders (Liners; wet or dry)	Dry Liners	Dry Liners	Dry Liners
Valve Configuration	Overhead Camshaft	Overhead Camshaft	Overhead Camshaft

DESCRIPTION	Hino 700 2038	Hino 700 2841	
-------------	---------------	---------------	--

TRANSMISSION

Make	ZF AS Tronic AMT	ZF AS Tronic AMT	ZF AS Tronic AMT
Model	16 AS2630TO	16 AS2630TO	16 AS2630TO
No of forward gears	16	16	16
Constant / Synchro mesh	Constant 1st - 16th	Constant 1st - 16th	Constant 1st - 16th
Gear Ratio (Low / High) 1:	14.120 / 0.827	14.120 / 0.827	14.120 / 0.827
Gearshift operation	Mech / Auto	Mech / Auto	Mech / Auto
PTO & Control	Non Standard	Non Standard	Non Standard
Reverse Ratio (Low / High) 1:	13.074 / 10.812	13.074 / 10.812	13.074 / 10.812

DESCRIPTION	Hino 700 2038	Hino 700 2841	
-------------	---------------	---------------	--

BRAKES

ABS	Yes	Yes	Yes
Brake system : Front	DRUM	DRUM	DRUM
Brake system : Rear	DRUM	DRUM	DRUM
Dual Circuit	Yes	Yes	Yes
Type :	Full air	Full air	Full air

DESCRIPTION	Hino 700 2038	Hino 700 2841	
-------------	---------------	---------------	--

STEERING

Ratio 1:	23.4	23.4	23.4
Steering Column	Tilt & Telescopic	Tilt & Telescopic	Tilt & Telescopic
Turning radius between kerbs : (mm)	6 200	7 200	7 200
Turning radius between walls : (mm)	7 100	8 100	8 100
Type	Power assisted; re-circulating ball	Power assisted; re-circulating ball	Power assisted; re-circulating ball

DESCRIPTION	Hino 700 2038	Hino 700 2841	
-------------	---------------	---------------	--

WHEELS & TYRES

Attachment	10 Stud ISO Type	10 Stud ISO Type	10 Stud ISO Type
Load Index (Single / Dual) Kg	3 750 / 3 750	3 750 / 3 350	3 750 / 3 350
Speed Index Km/h	130	130	130
No of Wheels including spare	7	11	11
Spare Wheel Fitment	Strapped to chassis	Strapped to chassis	Strapped to chassis
Tyre Construction	Radial Tubeless	Radial Tubeless	Radial Tubeless
Tyre size	315/80R22.5 156/150 M	315/80R22.5 156/150 M	315/80R22.5 156/150 M
Wheel size	9.00x22.5-offset 175mm	9.00x22.5-offset 175mm	9.00x22.5-offset 175mm
Wheel Type	Single Piece Steel	Single Piece Steel	Single Piece Steel

DESCRIPTION	Hino 700 2845	Hino 700 3541	
VEHICLE CONFIGURATION	6 X 4	8 X 4	
Application	Truck Tractor	Tipper	Freight Carrier
Suspensions	Steel	Steel	Steel
Cab	Single Sleeper Cab	Single Sleeper Cab	Single Sleeper Cab
Drivetrain	6x4	8x4	8x4

DESCRIPTION	Hino 700 2845	Hino 700 3541	
ENGINE			
Make and Model	Hino E13C TT	Hino E13C TN	Hino E13C TN
4 Stroke Compression Ignition	Yes	Yes	Yes
Aspiration	Turbo Intercooled	Turbo Intercooled	Turbo Intercooled
Bore X Stroke	137x146	137x146	137x146
Capacity (cc)	12 913	12 913	12 913
Compression Ratio : ~ : 1	17.5	17.5	17.5
Configuration	6 Cyl In Line	6 Cyl In Line	6 Cyl In Line
Engine oil cooler	Yes	Yes	Yes
Euro Emission Status	2	2	2
Firing order	1-4-2-6-3-5	1-4-2-6-3-5	1-4-2-6-3-5
Governor : All speed / RLD	Yes	Yes	Yes
Governor : Electronic	Yes	Yes	Yes
Injection System	Common Rail	Common Rail	Common Rail
Injector Pump	Electronic Control High Pressure Pump	Electronic Control High Pressure Pump	Electronic Control High Pressure Pump
Max Eng. Speed rpm	1 900	1 900	1 900
No of Main Bearings	7	7	7
Number of Cylinders	6	6	6
Number of Valves per Cylinders	4	4	4
Power (EEC/ISO NET) (kW @ r/min)	331 @ 1 800	302 @ 1 800	302 @ 1 800
Torque (Nm @ r/min)	2 157 @ 1 100	1 863 @ 1 100	1 863 @ 1 100
Type of Cylinders (Liners; wet or dry)	Dry Liners	Dry Liners	Dry Liners
Valve Configuration	Overhead Camshaft	Overhead Camshaft	Overhead Camshaft

DESCRIPTION	Hino 700 2845	Hino 700 3541	
TRANSMISSION			
Make	ZF AS Tronic AMT	ZF AS Tronic AMT	ZF AS Tronic AMT
Model	16 AS2630TO	16 AS2630TO	16 AS2630TO
No of forward gears	16	16	16
Constant / Synchro mesh	Constant 1st - 16th	Constant 1st - 16th	Constant 1st - 16th
Gear Ratio (Low / High) 1:	14.120 / 0.827	14.120 / 0.827	14.120 / 0.827
Gearshift operation	Mech / Auto	Mech / Auto	Mech / Auto
PTO & Control	Non Standard	Non Standard	Non Standard
Reverse Ratio (Low / High) 1:	13.074 / 10.812	13.074 / 10.812	13.074 / 10.812

DESCRIPTION	Hino 700 2845	Hino 700 3541	
BRAKES			
ABS	Yes	Yes	Yes
Brake system : Front	DRUM	DRUM	DRUM
Brake system : Rear	DRUM	DRUM	DRUM
Dual Circuit	Yes	Yes	Yes
Type :	Full air	Full air	Full air

DESCRIPTION	Hino 700 2845	Hino 700 3541	
STEERING			
Ratio 1:	23.4	25.2	25.2
Steering Column	Tilt & Telescopic	Tilt & Telescopic	Tilt & Telescopic
Turning radius between kerbs : (mm)	7 200	11 400	11 700
Turning radius between walls : (mm)	8 100	12 300	12 600
Type	Power assisted; re-circulating ball	Power assisted; re-circulating ball	Power assisted; re-circulating ball

DESCRIPTION	Hino 700 2845	Hino 700 3541	
WHEELS & TYRES			
Attachment	10 Stud ISO Type	10 Stud ISO Type	10 Stud ISO Type
Load Index (Single / Dual) Kg	3 750 / 3 350	3 750 / 3 350	3 750 / 3 350
Speed Index Km/h	130	130	130
No of Wheels including spare	11	13	13
Spare Wheel Fitment	Strapped to chassis	Temporary Bracket	Carrier on Chassis
Tyre Construction	Radial Tubeless	Radial Tubeless	Radial Tubeless
Tyre size	315/80R22.5 156/150 M	315/80R22.5 156/150 M	315/80R22.5 156/150 M
Wheel size	9.00x22.5-offset 175mm	9.00x22.5-offset 175mm	9.00x22.5-offset 175mm
Wheel Type	Single Piece Steel	Single Piece Steel	Single Piece Steel

DESCRIPTION	Hino 700 2038	Hino 700 2841	
REAR AXLE	4 x 2	6 X 4	6 X 4
Housing Type	Full Floating	Full Floating	Full Floating
Diff Lock (R1 & R2)	N/A	Yes (R1 & R2)	Yes (R1 & R2)
Inter-Axle Diff lock	N/A	Yes	Yes
Make	Hino	Hino	Hino
Ratio : 1	3,7	3,9	3,9
Type	Single Reduc - Hypoid	Single Reduc - Hypoid	Single Reduc - Hypoid

DESCRIPTION	Hino 700 2038	Hino 700 2841	
-------------	---------------	---------------	--

FUEL

Capacity (L)	390	840	840
--------------	-----	-----	-----

DESCRIPTION	Hino 700 2038	Hino 700 2841	
-------------	---------------	---------------	--

MASS DATA (KG)

A - Front	7 500	7 500	7 500
A - Rear	9 000	18 000	18 000
Approx. body + payload allowance	N/A	N/A	N/A
D/T	45 500	65 000	65 000
GA - Front	7 500	7 500	7 500
GA - Rear	13 000	21 800	21 800
GCM	45 500	65 000	65 000
GVM	19 500	28 300	28 300
Tare - Front	4 690	5 020	5 070
Tare - Rear	2 240	4 270	7 275
Tare - Total (incl. spare wheel)	7 099	8 986	9 046
V - rating	16 500	25 500	25 500

DESCRIPTION	Hino 700 2038	Hino 700 2841	
-------------	---------------	---------------	--

DIMENSIONS (MM)

BBC - Rear Structure	2 055	2 055	2 055
CA - Cab to Axle	2 805	2 505	2 505
CH - Cab Height	3 025	3 020	3 505
CW - Cab Width (excl. mirrors)	2 490	2 490	2 490
FH - Frame Height @ Rear Axle	1 030	1 010	1010
FOH - Front Overhang	1 380	1 380	1 380
FT - Front Track	2 030	2 030	2 030
RT - Rear Track	1 820	1 820	1 820
FW - Frame Width (Outside)	840	840	840
FWH - Fifth Wheel Height	1 310	1 335	1 335
Max. homologated body width	2 600	2 600	2 600
Maximum Body Length	N/A	N/A	N/A
Minimum Ground Clearance	240	255	255
OL - Overall Length	5 955	6 895	6 895
OVH - Overall Vehicle Height	3 025	3 020	3 505
ROH - Rear Overhang	935	835	835
WARW - Width Across Rear Wheels	2 480	2 480	2 480
WB - Wheel Base (FAS+WB+RAS)	3 480	3 180 + 1 350	3 180 + 1 350

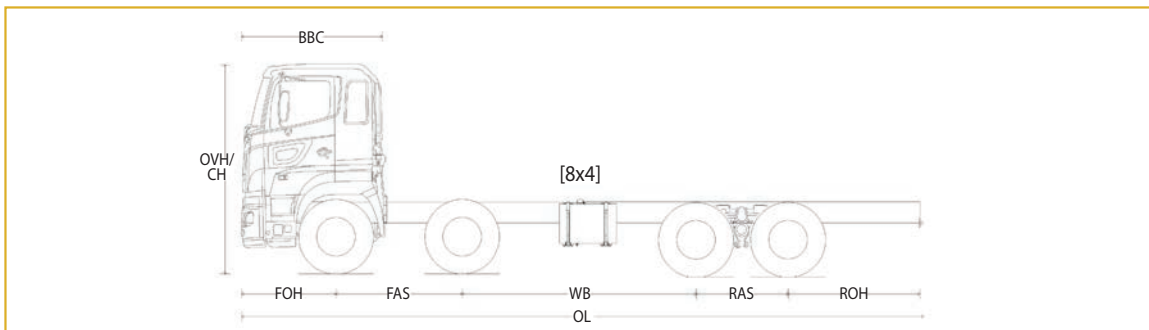
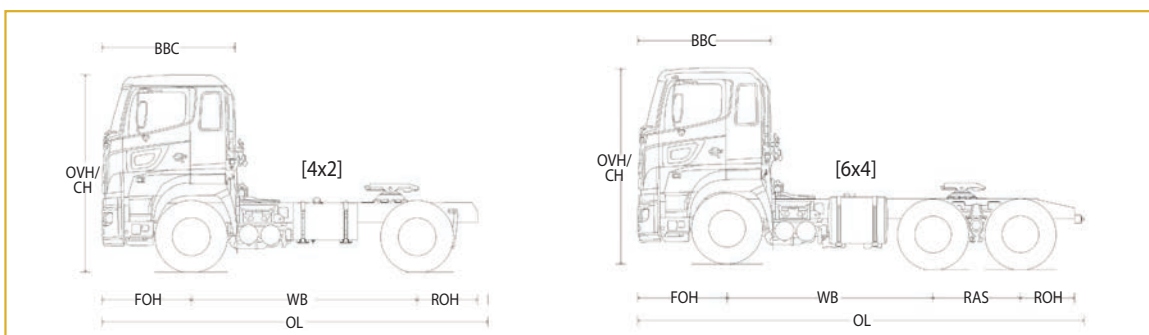

DESCRIPTION	Hino 700 2845	Hino 700 3541	
REAR AXLE	6 X 4	8 X 4	
Housing Type	Full Floating	Full Floating	Full Floating
Diff Lock (R1 & R2)	Yes (R1 & R2)	Yes (R1 & R2)	Yes (R1 & R2)
Inter-Axle Diff lock	Yes	Yes	Yes
Make	Hino	Hino	Hino
Ratio : 1	3.9	3,9	3,9
Type	Single Reduc - Hypoid	Single Reduc - Hypoid	Single Reduc - Hypoid

DESCRIPTION	Hino 700 2845	Hino 700 3541	
-------------	---------------	---------------	--

FUEL

Capacity (L)	840	330	330
--------------	-----	-----	-----

DESCRIPTION	Hino 700 2845	Hino 700 3541	
-------------	---------------	---------------	--

MASS DATA (KG)

A - Front	7 500	15 000	15 000
A - Rear	18 000	18 000	18 000
Approx. body + payload allowance	N/A	21 968	22 173
D/T	65 000	56 000	65 000
GA - Front	7 500	15 000	15 000
GA - Rear	21 800	21 800	21 800
GCM	65 000	57 000	65 000
GVM	28 300	35 000	35 000
Tare - Front	5 020	5 990	5 840
Tare - Rear	4 270	3 650	3 910
Tare - Total (incl. spare wheel)	8 986	9 640	9 740
V - rating	25 500	31 608	31 923

DESCRIPTION	Hino 700 2845	Hino 700 3541	
-------------	---------------	---------------	--

DIMENSIONS (MM)

BBC - Rear Structure	2 055	2 055	2 055
CA - Cab to Axle	3 180	5 130	5 280
CH - Cab Height	3 020	3 065	3 065
CW - Cab Width (excl. mirrors)	2 490	2 490	2 490
FH - Frame Height @ Rear Axle	1 095	1 100	1 100
FOH - Front Overhang	1 380	1 380	1 380
FT - Front Track	2 030	2 030	2 030
RT - Rear Track	1 820	1 820	1 820
FW - Frame Width (Outside)	840	840	840
FWH - Fifth Wheel Height	1 335	N/A	N/A
Max. homologated body width	2 600	2 600	2 600
Maximum Body Length	N/A	8 058	8 300
Minimum Ground Clearance	255	255	255
OL - Overall Length	6 895	9 045	9 995
OVH - Overall Vehicle Height	3 020	3 065	3 065
ROH - Rear Overhang	835	1 135	1 935
WARW - Width Across Rear Wheels	2 480	2 450	2 450
WB - Wheel Base (FAS+WB+RAS)	3 180 + 1 350	1 850 + 3 280 + 1 350	1 850 + 3 430 + 1 350

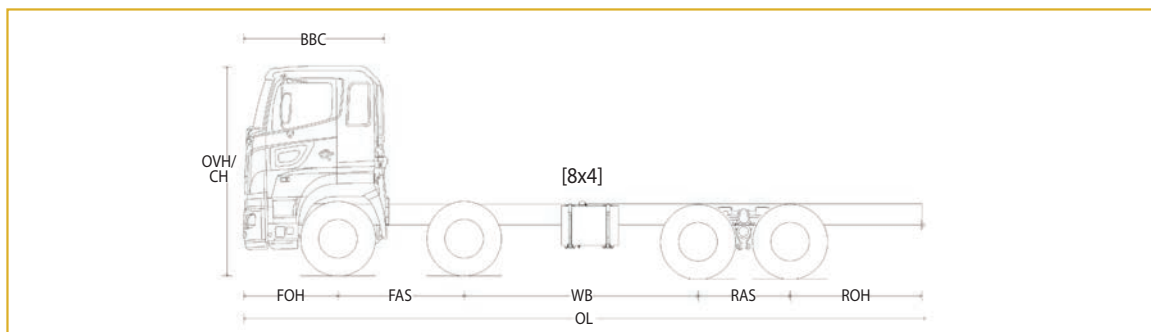
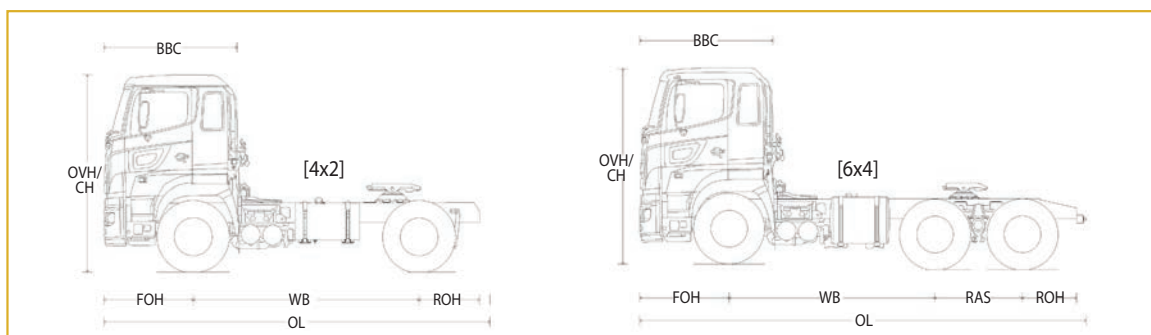

HEAVY DUTY TRUCKS THAT DELIVER

When the transport job requires more, the HINO 700 series is the truck that performs way above average.



Automated Manual Transmission

Engineered to transport Gross Combination Masses (GCM) between 45 - 65 tons, the HINO 700 series product line-up offers models to match a variety of heavy duty transport applications with 4x2, 6x4 and 8x4 drivetrains.

Euro 2 engine technology operating with an Automatic Manual Transmission ensures that this truck can meet most transport requirements in the extra heavy segment.

HINO 700 series, the right truck for AFRICA.



ABS standard



SRS Airbag (driver side)

1. PRODUCT RANGE LINE-UP

Engine:	12 913 cc
Configuration:	4x2, 6x4 and 8x4
Gross Combination Mass:	45 500 kg to 65 000 kg
Transmission:	16 speed ZF AS Tronic AMT
Suspension:	Steel

2. TECHNOLOGY

Emission:	Euro II
Fuel Injection:	Common Rail Technology
Aspiration:	Turbo-intercooled

3. SAFETY, COMFORT & CONVENIENCE

	STANDARD
ABS	✓
Air suspension driver seat	✓
Airconditioner	✓
Central locking	✓
Cruise control	✓
Electronic speed limiter	✓
In-cab storage space	✓
Power steering	✓
Power windows	✓
Radio/CD with speakers	✓
SRS Airbag (driver side)	✓
Tilt & telescopic steering column	✓



Spacious cab interior

Service intervals: Every 10 000 KM or as recommended by the selling HINO Dealer.

Disclaimer Information: Certain vehicle details and specifications contained in this leaflet may differ from available models.

HINO Motors Limited and Africa Mobility Solutions (Pty) Ltd. reserves the right to alter any details of specifications and equipment without notice.